



PB-31200-001B
Supersedes PB-31200-001A

GE Renewal Parts

Use original equipment parts for reliability

PARTS BULLETIN

**DRILLING MOTOR
MODEL 5GE761AJ3**

AUGUST 24, 2000

© Copyright 2000 General Electric Company. All rights reserved. This copyrighted document may be reproduced free of charge by General Electric Company customers, if such reproduction are used exclusively in connection with the operation and repair of GETS equipment used in that customer's internal operation.

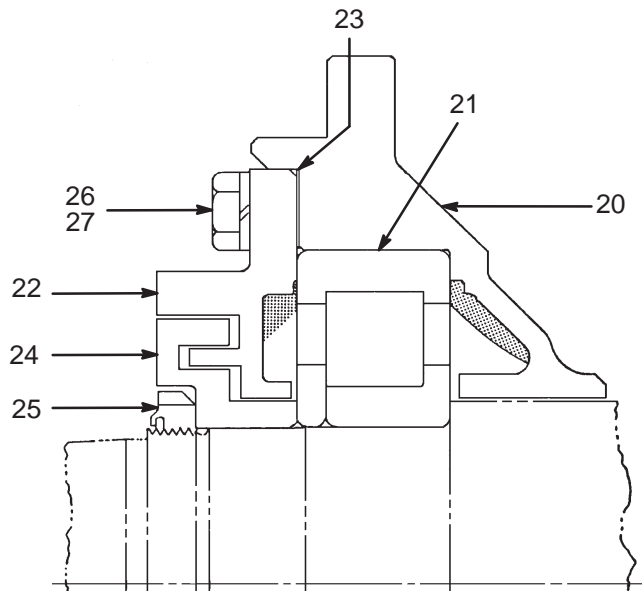

VIEW A

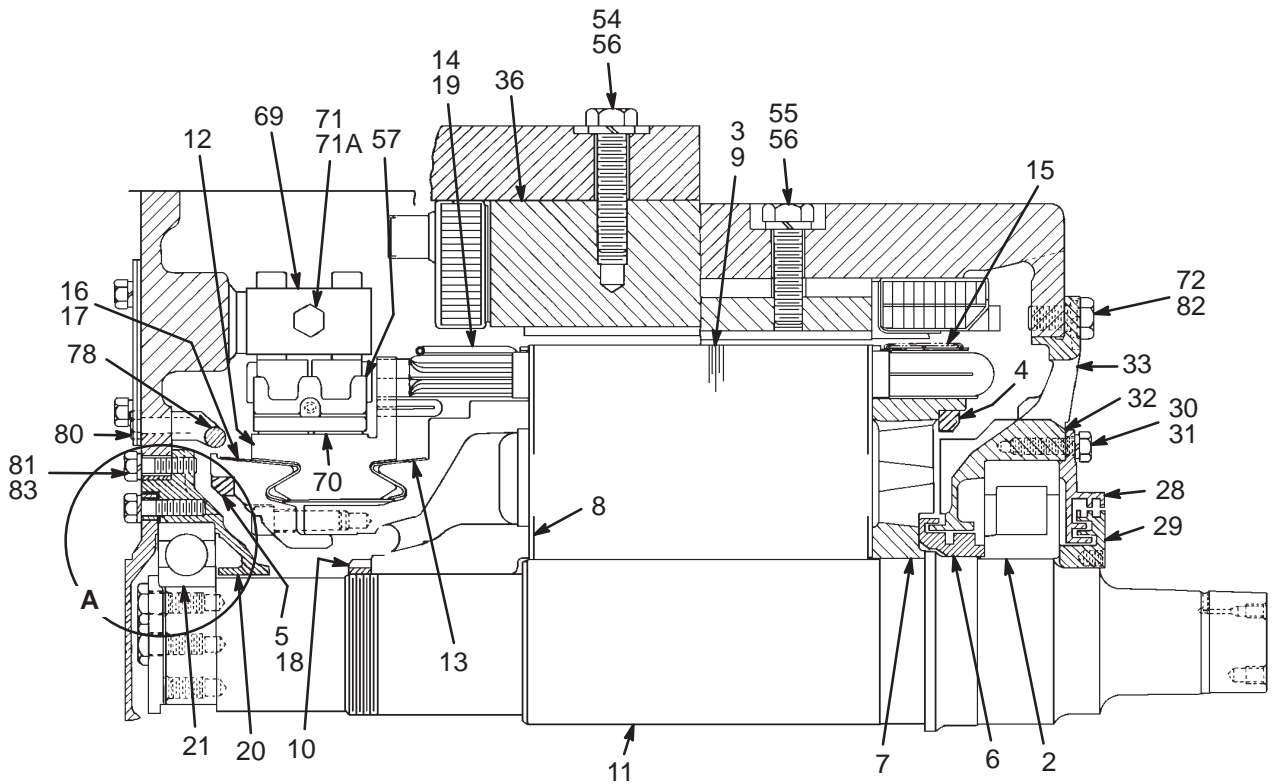

Ref. 1
(Representative Illustration)
Fig. 1

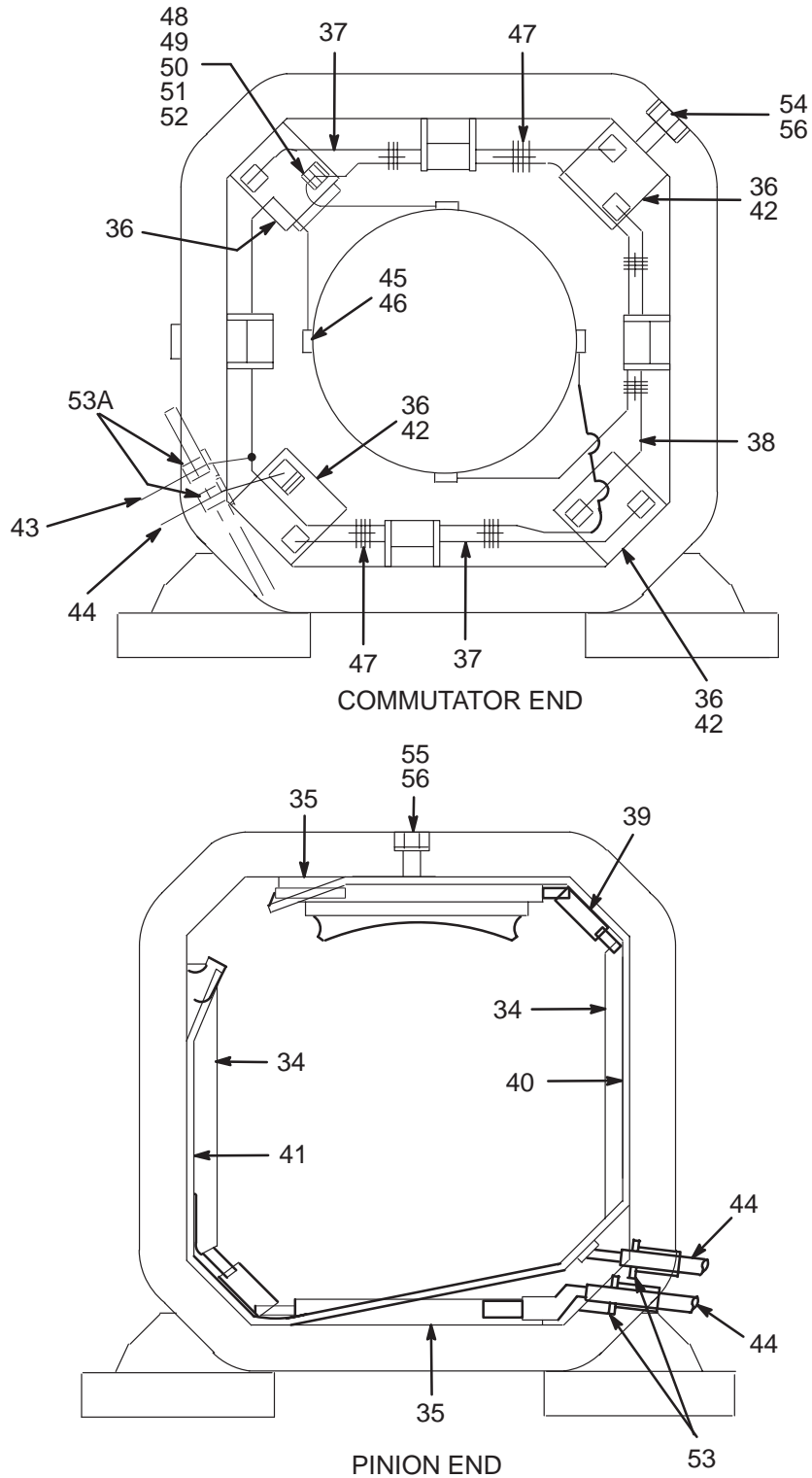

(Representative Illustration)
Fig. 2

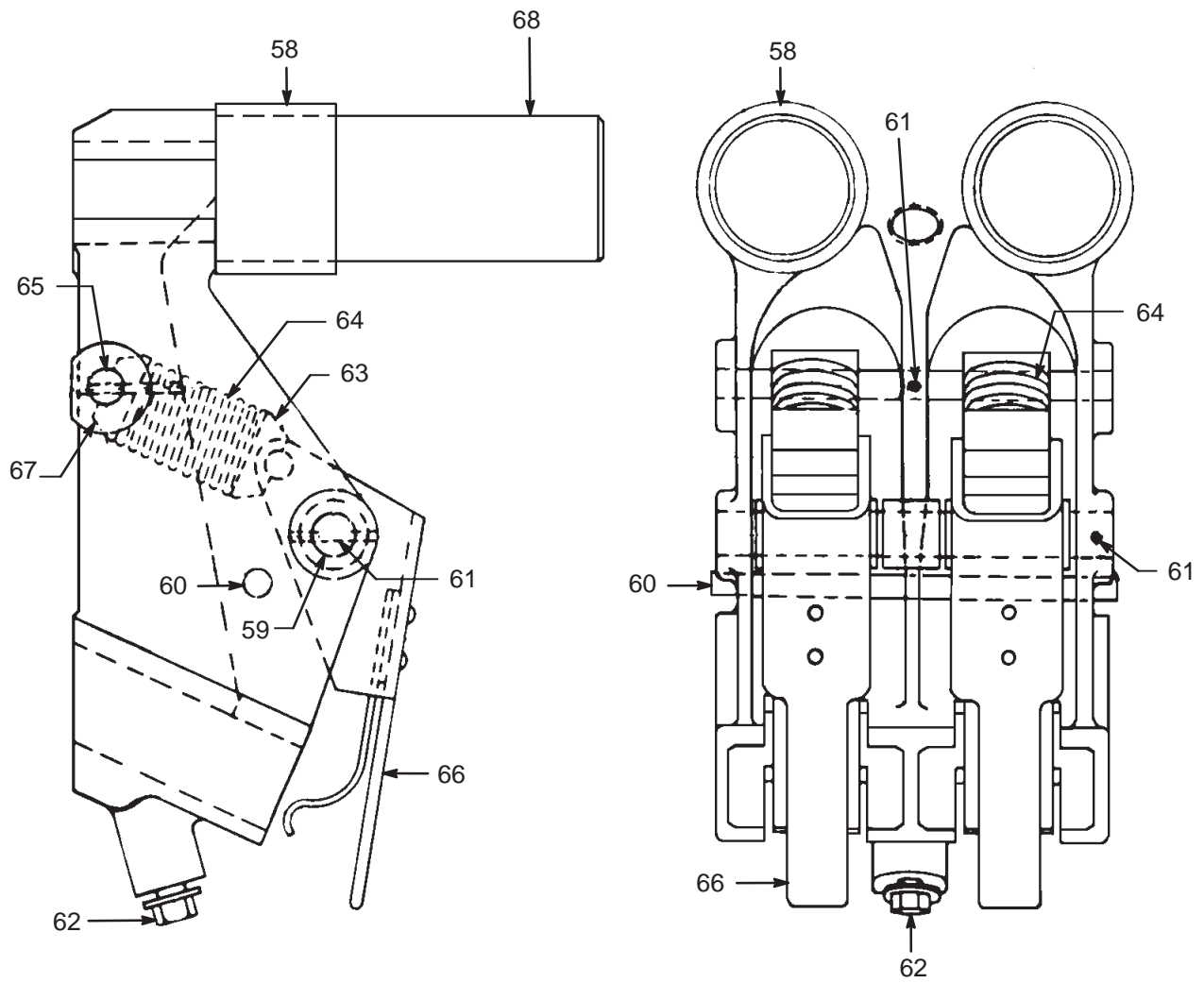

Ref. 57
(Representative Illustration)
Fig. 3

DRILLING MOTOR
MODEL 5GE761AJ3

PB-31200-001B
Supersedes PB-31200-001A

FIG. NO.	REF. NO.	PART NO.	QUANT REQ. COL. A	DESCRIPTION
1	1	5GE761AJ3	1	DRILLING MOTOR
1	2	8864951P148	1	ROLLER BEARING
1	3	41C630518G3	1	ARMATURE
1	4	2766829ADP43	AR	#BALANCE WEIGHT, 3/4 IN WIDE
1	5	2766829ADP14	AR	#BALANCE WEIGHT, 5/8 IN WIDE
1	6	41A231419P1	1	COLLAR
1	7	41C630398P1	1	ARMATURE HEAD
1	8	41B530027P1	2	END PUNCHING, 0.125 IN THICK
1	9	9949018P1	400	MAIN PUNCHING, 0.025 IN THICK
1	10	41A231420P1	1	NUT
1	11	41C630896G1	1	SHAFT
1	12	9949046G6	1	COMMUTATOR, SEASONED
1	13	41A239176P456	2	PERMAFIL PUTTY
1	14	41A239176P64	AR	GLASS TAPE, 0.014 IN THICK, 3/4 IN WIDE
1	15	41A330208P10	AR	WIRE, 0.072 IN DIA
1	16	41B537080P2	1	=TEFLON BAND (CONTINUOUS)
1	17	41A239176P60	AR	GLASS TAPE, 0.010 IN THICK, 1/4 IN WIDE
1	18	2766829AGP1	AR	#BALANCE WEIGHT, 21/32 IN WIDE
1	19	41D731384G5	1	REWIND KIT, ARMATURE
1	20	8843512P1	1	BEARING HOUSING
1	21	8864951P106	1	ROLLER BEARING
1	22	41B531153P1	1	BEARING CAP
1	23	8819143P1	1	GASKET
1	24	41B531152P1	1	COLLAR
1	25	41A232244P1	1	NUT
1	26	N22P29020B13	8	BOLT, HEX HD, 1/2 IN-13, 1 1/4 IN LONG
1	27	N405P45B13	8	LOCKWASHER, 1/2 IN
1	28	41B530705P1	1	BEARING CAP
1	29	41A231426P1	1	RETAINING COLLAR
1	30	N22P29020B13	6	BOLT, HEX HD, 1/2 IN-13, 1 1/4 IN LONG
1	31	N405P45B13	6	LOCKWASHER, 1/2 IN
1	32	8819142P1	1	GASKET, 12 7/8 IN DIA
1	33	41C630886P1	1	FRAME HEAD
2	34	8855153G12	2	COIL WITH POLE PIECE, EXCITING FIELD
2	35	8855153G14	2	COIL WITH POLE PIECE, EXCITING FIELD
1,2	36	8843549G4	4	COIL WITH POLE PIECE, COMMUTATING
1	37	9949030G1	2	CONNECTION STRAP
2	38	9949030G2	1	CONNECTION STRAP
2	39	41A235688G1	2	CONNECTION STRAP
2	40	41B532413G1	1	CONNECTION STRAP
2	41	41B532413G2	1	CONNECTION STRAP

WELD OR BRAZE IN POSITION.

= ADDITIONAL MATERIAL IS REQUIRED TO INSTALL THE CONTINUOUS LOOP TEFLON BAND. SEE APPLICATION INSTRUCTIONS, GEK-76278.

FIG. NO.	REF. NO.	PART NO.	QUANT REQ. COL. A	DESCRIPTION
		DELETED	8	*NOT USED
2	43	41B537974G9	1	*CABLE ASSEMBLY
2	44	41B539176G3	3	*CABLE ASSEMBLY
2	45	N22P29016B13	4	BOLT, HEX HD, 1/2 IN-13, 1 IN LONG
2	46	N405P45B13	4	LOCKWASHER, 1/2 IN
2	47	41A231248P1	4	PAD, 7/32 IN, 7/8 IN, 1 1/2 IN
2	48	41A239176P18	AR	TAPE, MICA, 0.005 IN THK, 0.750 IN WIDE
2	49	41A238861P1	2	PAD, INSULATION, 0.060 IN THICK
2	50	41A239176P443	AR	SILASTIC PUTTY
2	51	41A238861P3	15	INSULATION, 0.001 IN THK
2	52	41A231281P33	AR	BRAZING STRIP, 0.010 IN THK, 3/4 IN WIDE, 3/4 IN LG
2	53	481A539P36	2	*CABLE BUSHING, 1 IN ID, 29/32 IN OD, 1 1/2 IN
2	53A	481A539P37	2	*CABLE BUSHING, 1 IN ID, 1 29/32 IN OD, 2 1/8 IN
1,2	54	41A238308P1	8	BOLT, HEX HD, 7/8 IN-9
1,2	55	N22P37048	8	BOLT, HEX HD, 7/8 IN-9, 3 IN LONG
1,2	56	41B537660P19	16	WASHER, FLAT, 0.968 IN ID, 1.750 IN OD
1,3	57	41C637788G1	4	BRUSHHOLDER
3	58	41A232340P3	8	SLEEVE
3	59	41A231378P5	4	HINGE PIN, 3/8 IN DIA, 3 1/2 IN LONG
3	60	N509P2556	4	PIN, 1/4 IN DIA, 3 1/2 IN LONG
3	61	N509P1312	24	PIN, SPRING DOWEL, 1/8 IN DIA, 3/4 IN LONG
3	62	41A231439P4	4	BOLT WITH WASHER, 1/4 IN-20, 7/8 IN LONG
3	63	41A330248P1	8	SPRING SEAT
3	64	41A238759P1	8	SPRING
3	65	41A233880P5	4	HINGE PIN, 5/16 IN DIA, 3 1/2 IN LONG
3	66	41B532884G3	8	PRESSURE ARM
3	67	41A233867G5	8	SPRING SEAT WITH PIN
3	68	41B535754G41	8	BRUSH HOLDER STUD, MOLDED (0.002 IN OVERSIZE)
1	69	8828693P3	4	SUPPORT, BRUSH HOLDER
1	70	41A238548P1	8	CARBON BRUSH
1	71	N170P35052	4	BOLT, HEX SOC HD, 3/4 IN-10, 3 1/4 IN LONG
1	71A	41B537660P16	4	*WASHER, FLAT, 0.850 IN ID, 1.375 IN OD
1	72	41B537660P14	7	*WASHER, FLAT, 0.850 IN ID, 1.188 IN OD
		41A232221G1	1	INSPECTION COVER, 8 9/16 IN X 11 7/8 IN LONG
		41A239176P318	AR	GASKET, PRE-COATED FELT, 0.250 IN THK
		41A232217G2	1	INSPECTION COVER, 5 15/16 IN X 11 1/4 IN LONG
		41A239176P318	AR	GASKET, PRE-COATED FELT, 0.250 IN THK
		41A232214P1	1	COVER, 9 3/4 IN LONG, HAND HOLE
1	78	41A231453G1	1	FLASH RING
		N22P29014B13	4	BOLT, HEX HD, 1/2 IN-13, 7/8 IN LONG
1	80	N22P29020B13	6	BOLT, HEX HD, 1/2 IN-13, 1 1/4 IN LONG
1	81	N22P29028B13	8	BOLT, HEX HD, 1/2 IN-13, 1 3/4 IN LONG

* ADDED OR CHANGED SINCE LAST ISSUE.

DRILLING MOTOR
MODEL 5GE761AJ3

PB-31200-001B
Supersedes PB-31200-001A

FIG. NO.	REF. NO.	PART NO.	QUANT REQ. COL. A	DESCRIPTION
1	82	8808885P1	7	*BOLT, HEX HD, 3/4 IN-10, 1 1/2 IN LONG
1	83	N405P45B13	12	LOCKWASHER, 1/2 IN

* ADDED OR CHANGED SINCE LAST ISSUE.

- END OF PARTS BULLETIN -

PB-31200-001B
Supersedes PB-31200-001A

DRILLING MOTOR
MODEL 5GE761AJ3
