



GE Renewal Parts

Use original equipment parts for reliability
PARTS BULLETIN

UNCONTROLLED COPY

See On-Line Master for Current Revision

MOTOR MODEL 5GEB22A2

15-OCT-2003

(c) copyright 2002 General Electric Company. All rights reserved. This copyrighted document may be reproduced free of charge by General Electric Company customers, if such reproductions are used exclusively in connection with the operation and repair of GETS equipment used in that customer's internal operation.

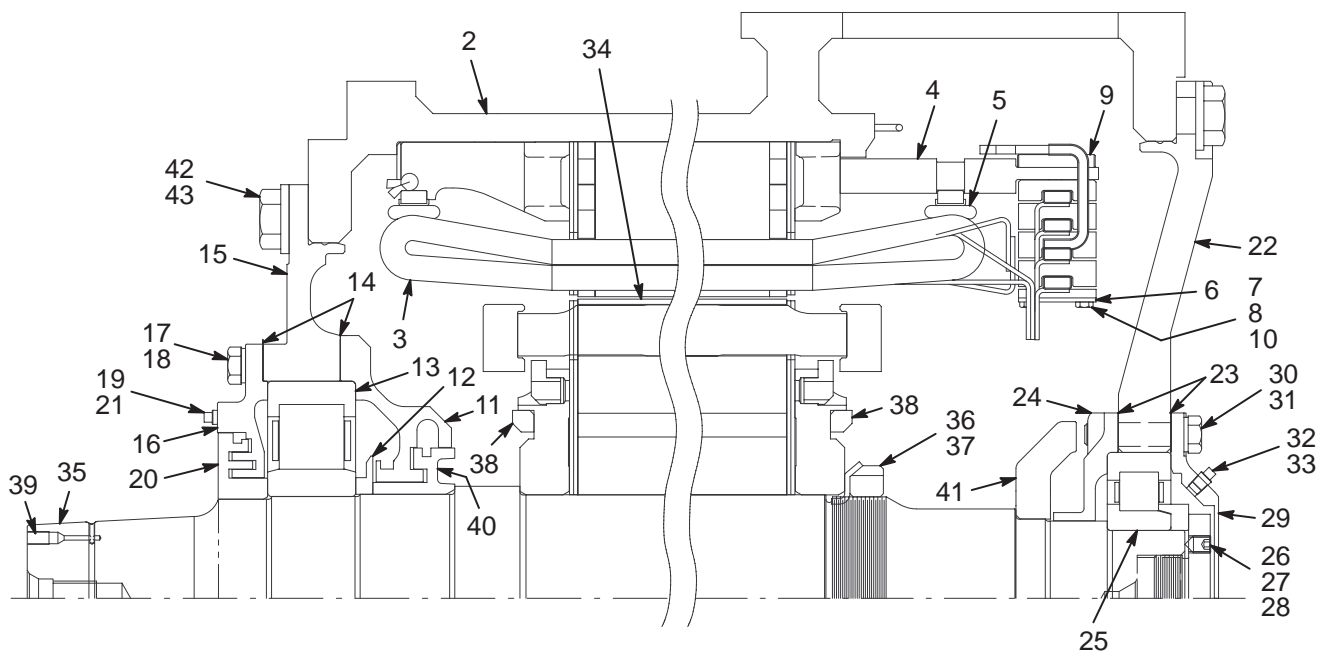

Ref. 1
(Representative Illustration)
FIG. 1

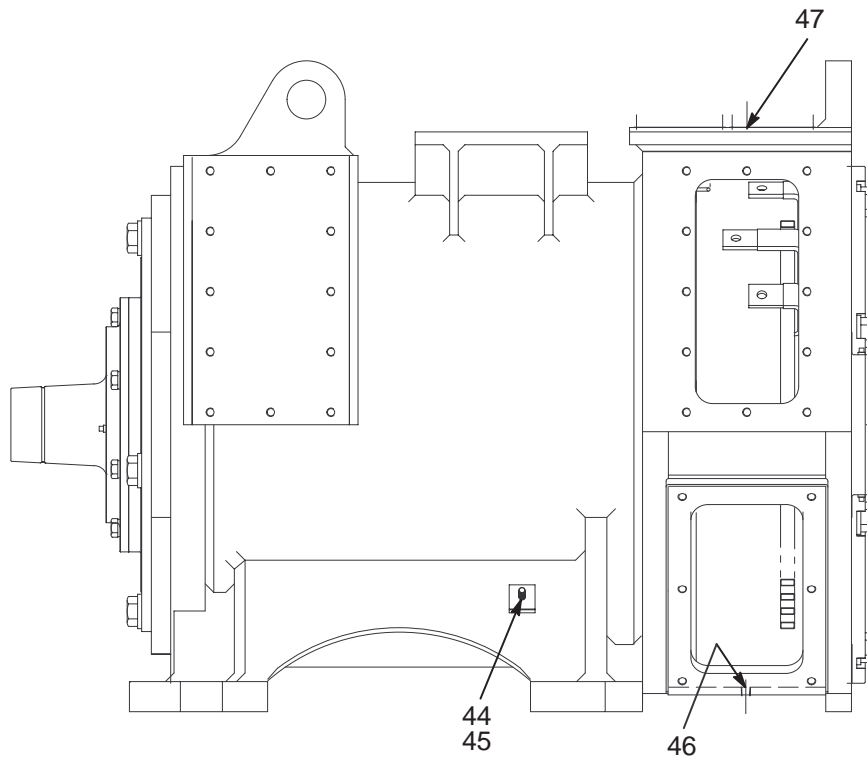
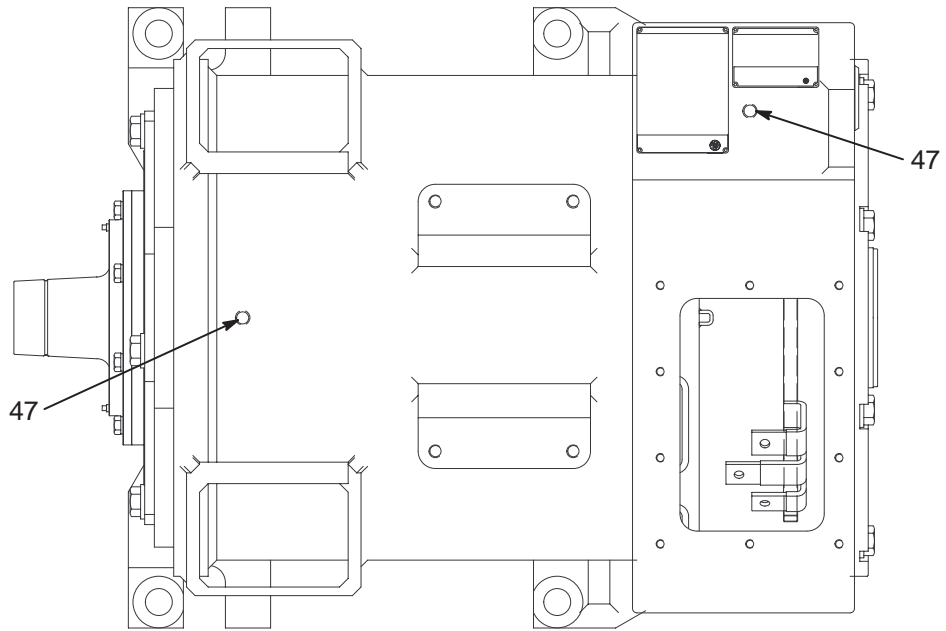

(Representative Illustration)
FIG. 2

UNCONTROLLED COPY
MOTOR MODEL 5GEB22A2
See On-Line Master for Current Revision

PB-31107-004

FIG. NO.	REF. NO.	PART NO.	QTY	DESCRIPTION
1	1	5GEB22A2	1	MOTOR, AC (SEE PB-31107-004)
1	2	41E903972G1	1	STATOR ASSEMBLY
1	3	41E903972G2	1	STATOR ASSEMBLY REWIND KIT
1	4	84B512931P1	6	BUS RING SUPPORT POST, 8 1/2 IN LONG
1	6	84A205426P1	6	CLAMP BAR, 3/4 IN WIDE, 2 1/4 IN LONG
1	7	N22P21072B13	12	BOLT, HEX HD, 1/4 IN-20, 4 1/2 IN LONG
1	8	N405P41B13	12	LOCKWASHER, 1/4 IN
1	9	84A205424P1	6	TAP BLOCK, 3/4 IN WIDE, 2 1/4 IN LONG
1	10	497A806P83	AR	CEMENT
1	11	6744700P2	1	BEARING CAP, INNER
1	12	4713640P1	1	FLINGER, 8 1/4 IN OD
1	13	8864951P167	1	ROLLER BEARING
1	14	4732906P1	2	GASKET, 0.021 IN THICK, 15 IN OD
1	15	41C637314P1	1	FRAME HEAD
1	16	84B512960P1	1	BEARING CAP
1	17	41B537660P9	8	WASHER, FLAT, 0.725 IN ID, 1 IN OD
1	18	N22P33060	8	BOLT, HEX HD, 5/8 IN-11, 3 3/4 IN LONG
1	19	N5700P21	2	PIPE PLUG, SQ HD, SOLID, 1/8 IN
1	20	4732351P1	1	SLEEVE, 9 7/32 IN OD
1	21	497A806P87	AR	SEALANT
1	22	84D706971P1	1	FRAME HEAD
1	23	4732368P1	2	GASKET, 0.021 IN THK
1	24	334B761P1	1	BEARING CAP
1	25	8864951P119	1	ROLLER BEARING
1	26	84B515283P1	1	BEARING CLAMP
1	27	41B537660P6	4	WASHER, FLAT, 0.562 IN ID, 0.938 IN OD
1	28	N22P29020B13	4	BOLT, HEX HD, 1/2 IN-13, 1 1/4 IN LONG
1	29	84B515189P1	1	BEARING CAP
1	30	41B537660P9	8	WASHER, FLAT, 0.725 IN ID, 1 IN OD
1	31	N22P33048B13	8	BOLT, HEX HD, 5/8 IN-11, 3 IN LONG
1	32	N5700P21	2	PIPE PLUG, SQ HD, SOLID, 1/8 IN
1	33	497A806P87	AR	SEALANT
1	34	84C620926G4	1	ROTOR ASSEMBLY
1	35	84D730122P2	1	SHAFT
1	36	8864959P130	1	LOCKWASHER
1	37	8864959P30	1	NUT
1	38	2766829ADP14	AR	BALANCE WEIGHT, 5/8 IN WIDE
1	39	84A204808P1	1	SET SCREW, HEX SOC HD, 3/8 IN-24, SELF-LOCK
1	40	41A232821P1	1	SLEEVE
1	41	84B512988P1	1	COLLAR
1	42	N22P39032	12	BOLT, HEX HD, 1 IN-8, 2 IN LONG
1	43	41B537660P21	12	WASHER, FLAT, 1.063 IN ID, 2 IN OD
2	44	41A235078P57	2	STUD, 3/8 IN-16, 1 3/4 IN LONG
2	45	497A806P78	AR	THREADLOCKER 271, HIGH STRENGTH
2	46	N5700P31	2	PIPE PLUG, SQ HD, 1/4 IN
2	47	N5700P51	2	PIPEPLUG, SQ HD, 1/2 IN
0	48	493A471P1	1	HUB, 9.120 IN OD, POWER TAKE-OFF

15-OCT-2003